

ACCU-LINE

Model 'A' Injection System

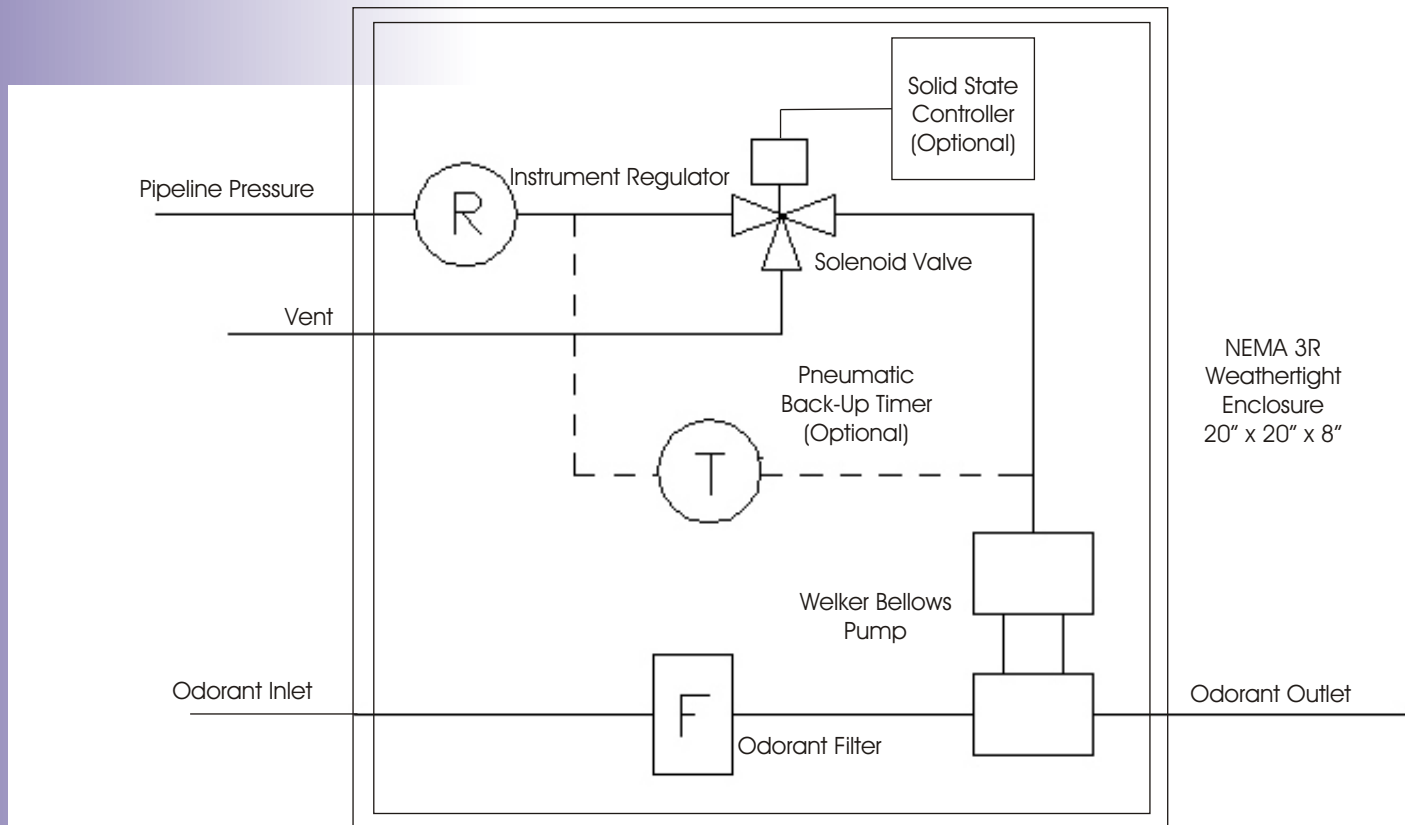

OdorEyes basic 'Model A' system includes an instrument regulator, 3-way solenoid valve, bellows injection pump and liquid filter, enclosed in a NEMA 3R weather tight cabinet with vent kit and drip shield (20" x 20" x 8")

OdorEyes Technologies is bringing you a new approach to buying!!

Tired of hearing from the manufacturer that this is the only model we have .. Take it or leave it!! Now you can order the odorant system that **you** want, one that fits **your** needs and specifications. Start with the basic 'Model A' shown above, design the system you need, add the options you want and order. Simple ... Safe ... and Easy!! We will be happy to work with you on options, design specifications and technical advice ... Just give us a call. With OdorEyes you now have a choice!!

More than 20 years of solid performance characterize the injection odorizers manufactured by OdorEyes Technologies. With the introduction of the Welker BIP bellows injection pumps, OdorEyes injection systems have taken accuracy, performance and simplicity to the next level. As always ... OdorEyes will continue to offer the quality, performance and customer service that you have come to expect.

NOW ... YOU CHOOSE !!!



13839 West Bellfort
Sugar Land, TX 77478
Ph: 281-491-3409
Fax: 281-491-8344
1-877-ODORIZE

Model 'A' Injection Basic System:

Pump cabinet (20"x 20"x 8") NEMA 3R weather tight with vent kit and drip shield.

System accepts only a pulse from the user's gas meter or flow computer. Pulse must have a minimum 0.75 dwell to allow the pump to make a full stroke.

Regulator.

Solenoid Valve (Specify 120 VAC, 24 VDC or 12 VDC).

Bellows Injection Pump (1/4" or 1/2").

Liquid Filter.

Pump Cabinet Options:

Pneumatic Back-up Timer.

Sight Flow assembly with Diffuser Probe.

Tank Blanket Regulator Installed.

Welker F-5 Filter/Separator, mounted & piped.

3/4" Bellows Pump.

Pulse Input Controller with Back-Up (Option):

Explosion proof enclosure (6"x 6"x 4") mounted on pump cabinet with Welker Model 4P solid state timer.

System is fully battery powered.

Accepts pulse from user's gas meter. If meter signal is lost, system can switch to constant operation (manual).

Fully assembled including electronics, solenoid and battery.

Analog Input Controller (Option):

Explosion proof enclosure mounted on pump cabinet with Welker Model 4P solid state controller.

System can accept 4-20 ma or 1-5 VDC input from user's gas meter and will integrate and pulse the pump proportional to flow. If meter signal is lost, system can switch to constant operation (manual).

Includes 12 VDC solenoid, battery back-up and power supply.

Fully assembled with solar power system.

Build your own system, pick and choose the options you want. OdorEyes will work **with you** to build a system to fit your needs and specifications.

OdorEyes BIP Bellows Pump

The OdorEyes BIP Series of Injection Pumps are displacement pumps used to inject a liquid chemical into a pressurized pipeline. Odorant, acid, methanol and inhibitor chemicals are just a few of the products that can be injected with the BIP Series of pumps. The BIP incorporates a Teflon bellows that separates the chemical being injected from the working side of the pump, as well as from the outside environment. Thus, the hydraulic piston and seals are not subjected to the harsh environments of the chemicals which will in-turn prolong seal life and minimize the downtime needed for repairs. Unwanted leaks, odors and spills are maintained within the bellows, maximizing environmental protection.